

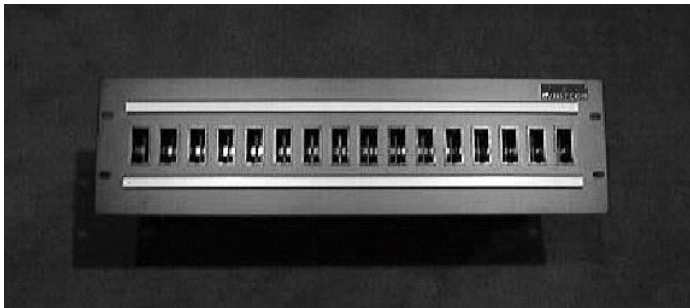

**MARK II Dynapatch®
EP-1T Analyzer Access Panel**

Mark II Dynapatch® EP-1T Analyzer Access Panel

The Dynetcom range of Mark II patch equipment provides the user with fast and simple monitoring access to any connected circuits. Up to 16 circuits may be attached to the RA-2T panel, which supports a variety of interfaces running up to 2 Mbps. By use of a "T" connection on the through circuit the EP-1T, allows the user non-interruptive access for monitoring by simply inserting a Dynetcom MK II patch cord with analyzer interface connector* into the appropriate patch jack.



RA-2T Front View

Shown fitted with sixteen EP-1T Dynapatch® modules

By using interface adaptors the EP-1T will support a large range of interface types using the DB25, DB15, DB37, Winchester V.35, RJ45 or BNC physical connectors.

* The Dynetcom patch cord may be fitted with DB25, DB15, or Winchester V35 connectors to interface to different analyzers.

RA-2T Rear View

Shown fitted with EP-1T Winchester V.35, DB15, RJ45, DB25, and BNC interface modules

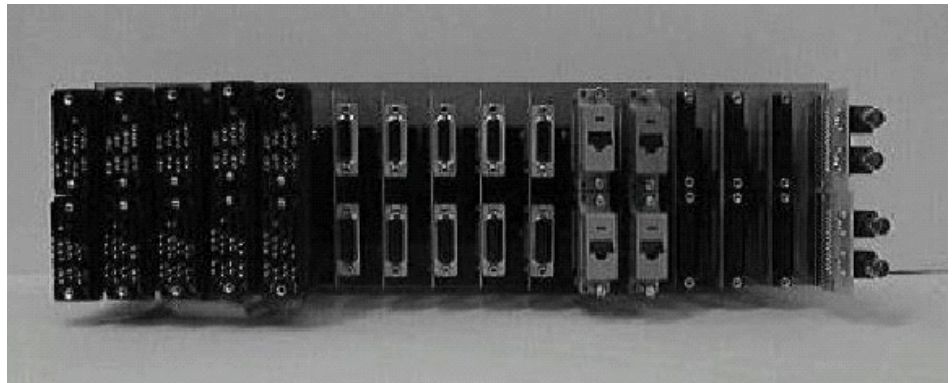

Communication solutions from

NSGDatacom

extend. evolve. innovate.



MARK II Dynapatch® EP-1T Analyzer Access Panel

The RA-2T is a 19" rack mounted panel and may be fitted with the following interface modules:

EP-1T	V.24 module for speeds up to 64Kbps fitted with DB25 connectors
EP-1T.21	V.11 (X.21) module for speeds up to 2Mbps with DB15 connectors
EP-1T.35	V.35 module for speeds up to 2Mbps with Winchester V.35 connectors
EP-1T.45	RJ45 module for speeds up to 2Mbps DB25 to RJ45 adapters
EP-1T.449	RS449 (V.36) module for speeds up to 2Mbps DB25 to DB37 adapters
EP-1T.Coax	G703 module for speeds up to 2 Mbps DB25 to dual BNC adapters

Typical EP-1T Configuration

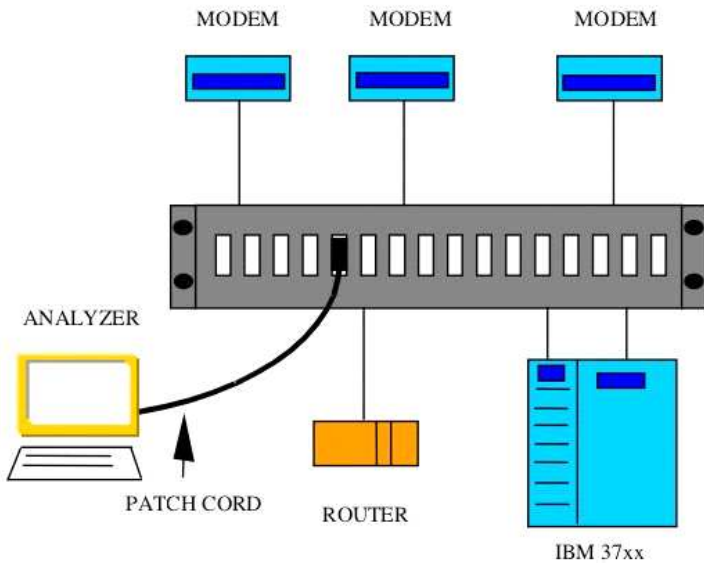

Specifications:

Rack mountable 3U 19" RA-2T Access panel with up to 16 channels for monitoring, using the Dynapatch® EP-1T jack

Interfaces Supported:

V.24, RS232, V.35, X.21, V.11, V.36, RS449, RS530, G703/10baseT

The Mark II Dynapatch® EP-1T patch jacks are guaranteed against defects in material and workmanship for the life of the original installation.

NSGDatacom

www.nsgdata.com

3863 Centerview Drive
Chantilly, VA, 20151-3232 USA
Phone: +(1) 703 793 2000
Fax: +(1) 703 793 2001

7435 New Technology Way
Frederick, MD, 21703 USA
Phone: +(1) 301 662 5926
Fax: +(1) 301 694 6279

The Brackens, London Road
Ascot, Berkshire SL5 8BE, UK
Phone: +(44) 1344 893 000
Fax: +(44) 1344 891 990